

New Easy to Use Format!

FLASH CARDS

CHEROKEE syllabary

D _a	R _e	T _i	Ḍ _o	O _u	i _{lv}
S _{ga} Ḍ _{ka}	R _{go}	Y _{gi}	A _{go}	J _{gu}	E _{gv}
ḥ _{na}	P _{he}	A _{hi}	H _{ho}	T _{hu}	A _{hv}
W _{la}	ḍ _o	F _{li}	G _{lo}	M _{lu}	A _{lv}
ḥ _{ma}	A _{mo}	H _{mi}	ḥ _{mo}	Y _{nu}	O _{nv}
Ḍ _{na} ḥ _{na} Ḡ _{nah}	A _{no}	h _{ni}	Z _{no}	A _{nu}	O _{nv}
T _{qua}	Ḍ _{que}	P _{qui}	W _{quo}	Ḍ _{qu}	E _{quv}
H _{sa} Ḍ _s	A _{so}	b _{si}	F _{so}	ḥ _{su}	R _{sv}
L _{da} W _{la}	S _{de} T _{do}	J _{di} J _{ti}	V _{do}	S _{du}	O _{dv}
Ḍ _{dia} L _{ti}	L _{ti}	C _{lli}	ḥ _{ti}	P _{ti}	P _{tlv}
Ḡ _{isa}	V _{iso}	H _{tsi}	K _{iso}	J _{tsu}	C _{lsv}
Ḡ _{wa}	Ḍ _{wa}	Ḍ _{wi}	Ḍ _{wo}	J _{wu}	Ḡ _{wv}
Ḍ _{ya}	B _{yo}	ḥ _{yi}	A _{yo}	Ḡ _{yu}	B _{yv}

Cherokee Language & Culture
 4158 E. 43rd Place
 Tulsa, Oklahoma 74135-4739
 www.cherokeemadepasy.com

Published by
 Cherokee Language & Culture
 Phone: 918-749-3082



\$ 10.95

LEARN THE CHEROKEE SYLLABARY
by *Easy*
PICTURE ASSOCIATION

This study tool aids in learning and remembering the syllabary through visual association. The symbol and its phonetic tone is shown in a picture that serves as a key to quick recall.

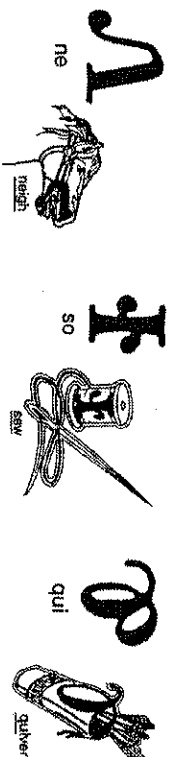

Examples show how the learning progresses from: seeing the syllable in picture form, hearing the phonetic tone, and recalling the shape and sound of the Cherokee syllable.

ALL RIGHTS RESERVED BY:
Cherokee Language and Culture
Prentice Robinson
Copyright 1998, 2010
Reproduction in any form is strictly prohibited by
copyright law.

CHEROKEE SYLLABARY

D _a S _{ga} ʔka F _{ha} W _{la} ʔ _{na} ʔ _{na} t _{hna} G _{na} T _{qua} E _{sa} ʔ L _{da} W _{ta} ʔ _{dia} L _{tia} G _{tsa} G _{wa} ʔ _{ya}	R _e F _{go} P _{he} ʔ _{le} A _{me} A _{ne} ʔ _{que} A _{se} S _{do} T _o L _{tle} T _{se} ʔ _{we} B _{ye}	T _i Y _{gi} ʔ _{hi} F _{li} H _{mi} h _{ni} P _{qui} B _{si} I _{di} J _{ti} C _{ti} K _{tsi} ʔ _{wi} ʔ _{yi}	ʔ _o A _{go} F _{ho} G _{lo} ʔ _{mo} Z _{no} ʔ _{quo} F _{so} V _{do} ʔ _{tle} K _{tsa} ʔ _{wo} ʔ _{yo}	O _u J _{gu} T _{hu} M _{lu} Y _{ru} ʔ _{nu} ʔ _{qu} ʔ _{su} S _{du} ʔ _{tu} J _{tsu} ʔ _{wu} G _{yu}	I _v E _{gv} ʔ _{hv} ʔ _{lv} O _{nv} ʔ _{quv} R _{sv} ʔ _{dv} P _{tlv} C _{tsv} G _{wv} B _{vv}
---	---	--	---	---	--

CHEROKEE SYLLABARY phonetics are represented

by Vowels:

- a, as a in father, or short as a in rival
- e, as a in hate, or short as e in met
- i, as i in pique, or short as i in pit
- o, as o in note, approaching aw in law
- u, as u in fool, or short as u in pull
- v, as v in but, nasalize

by Consonants:

- g nearly as in English, but approaching to k. d nearly as in English but approaching to t.
- hktmngstwyasin English.
- Syllables beginning with g except (ga), at times the power of k.
- (go), (du), (dv) are sometimes sounded to, th, ty, and syllables written with tl except (tia) sometimes vary to dl.

For further Information or related study materials on the language, history, and culture, contact:

Cherokee Language & Culture
 Prentice & Willena Robinson
 4158 East 48 Place
 Tulsa, Oklahoma 74135-4739
 (918) 749-3082

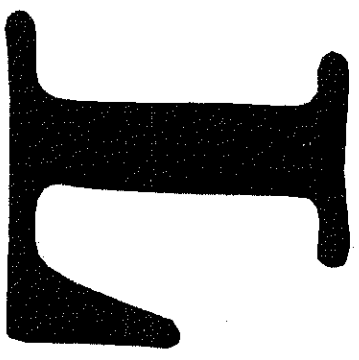

tle

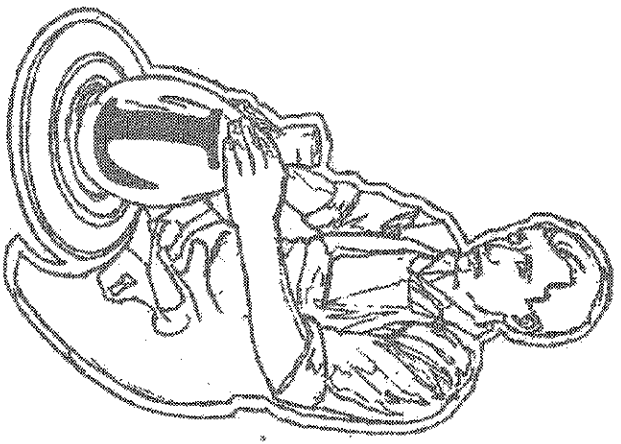

clay

My thanks to my wife for encouragement, and to Doug Latta for his assistance in the final drawings.

de S

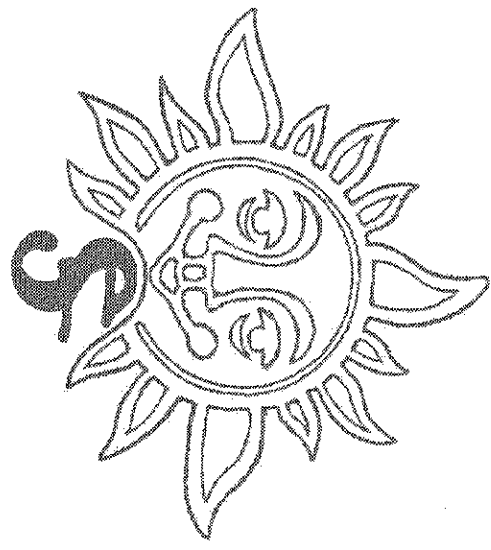

day

mo I

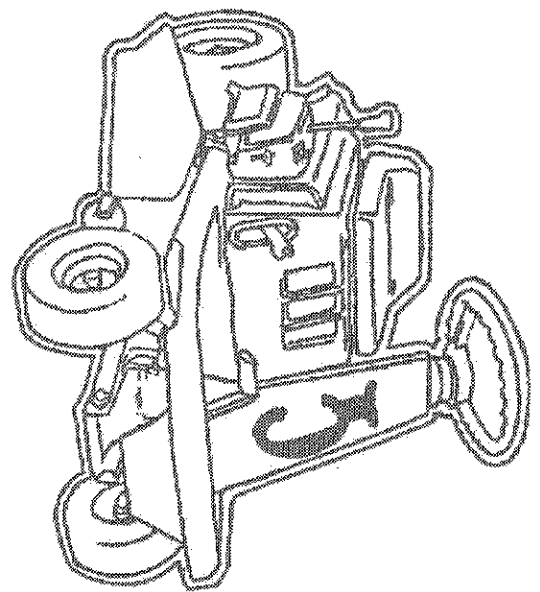

mower

T

te

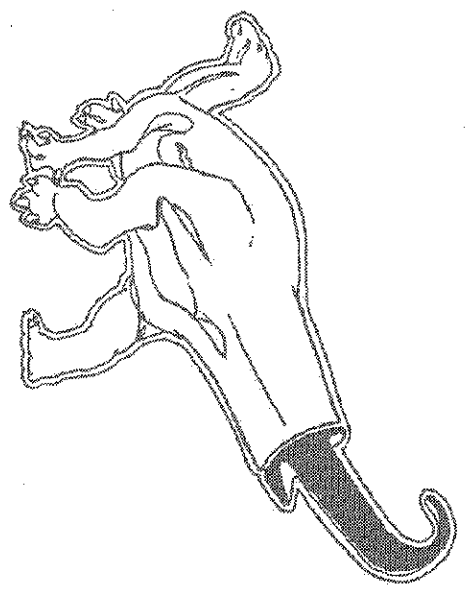

tail

A

mu

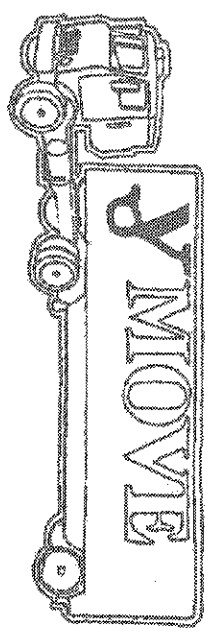

move

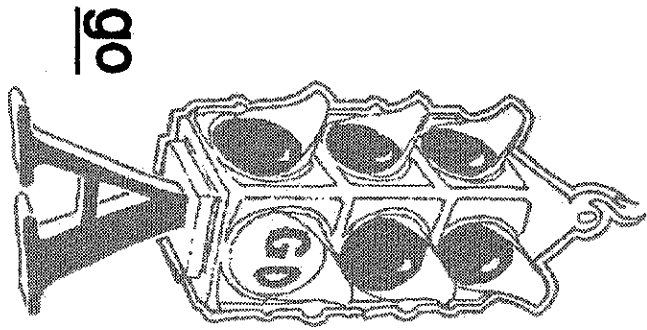

go

go

A

gun

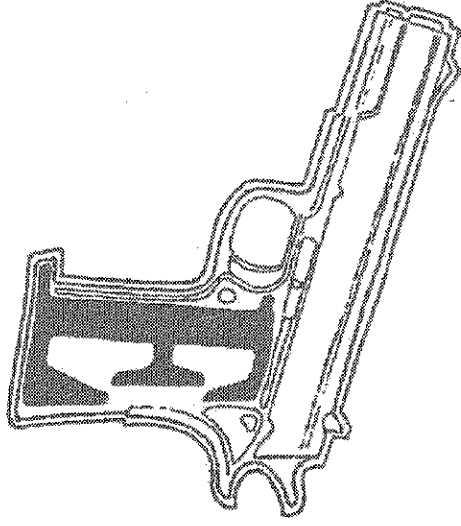

gv

E

gift

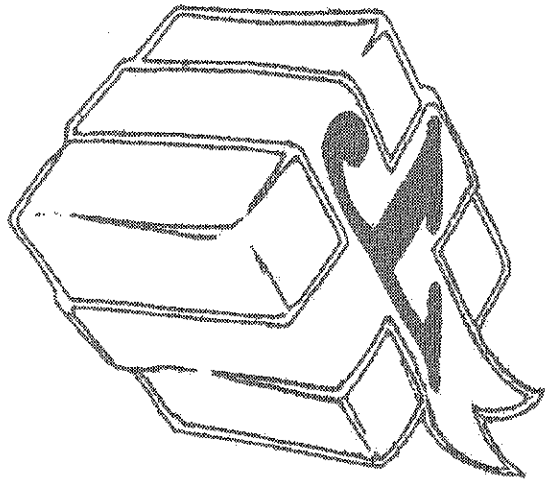

gi

A

goose

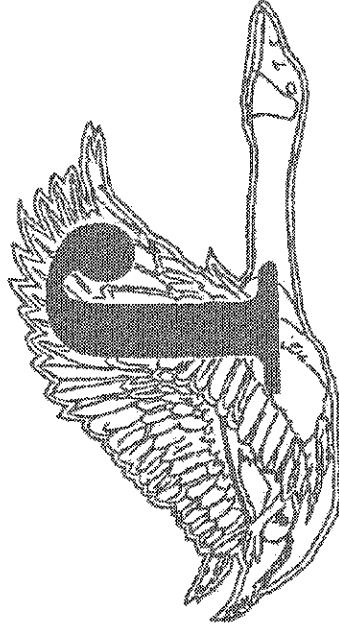

gu

J

ladle

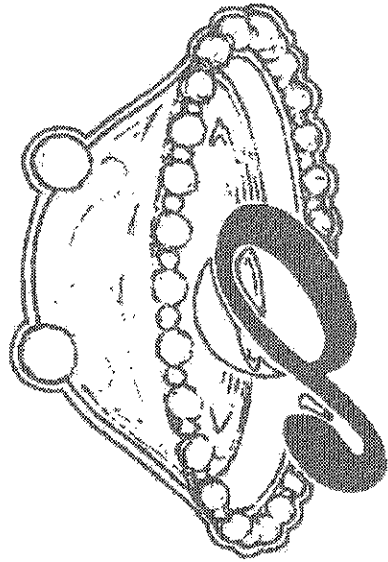

le

l

hoo

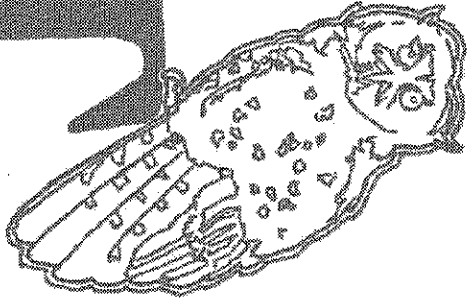

hu

h

hubcap

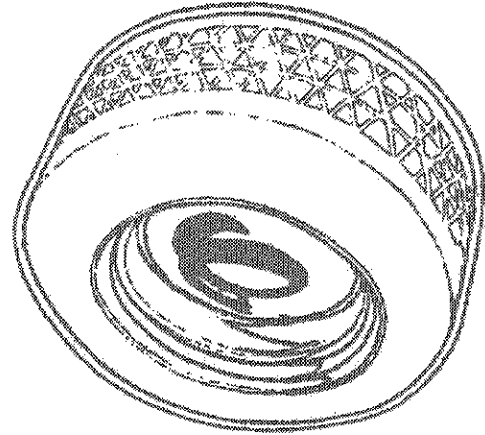

hv

h

hitter

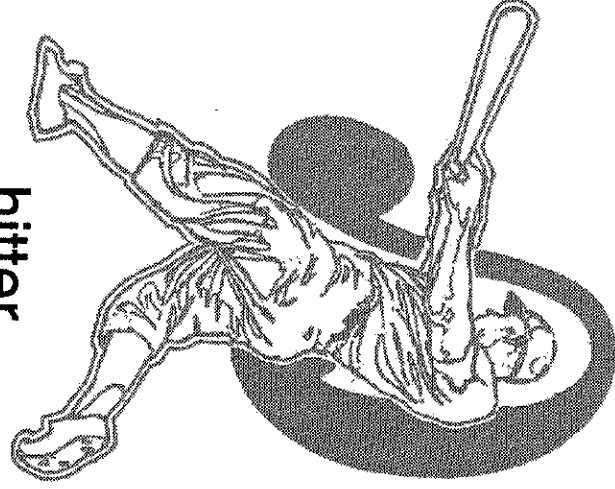

hi

h

ka

ka

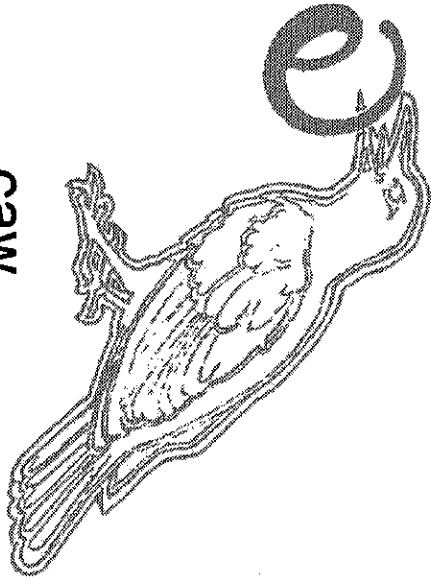

caw

lo

lo

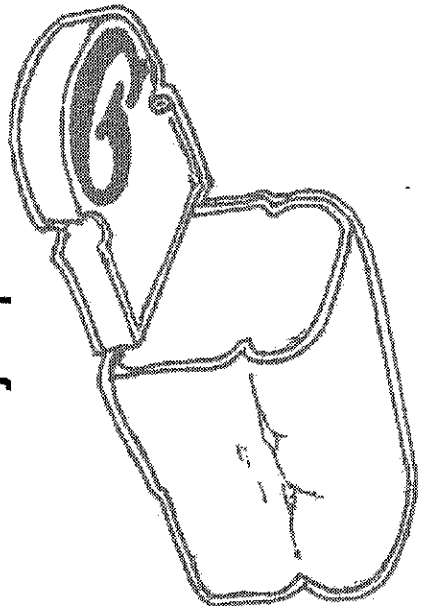

loaf

ge

ge

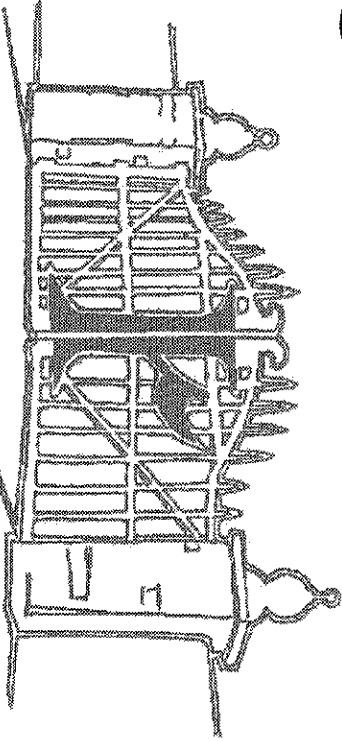

gate

lv

lv

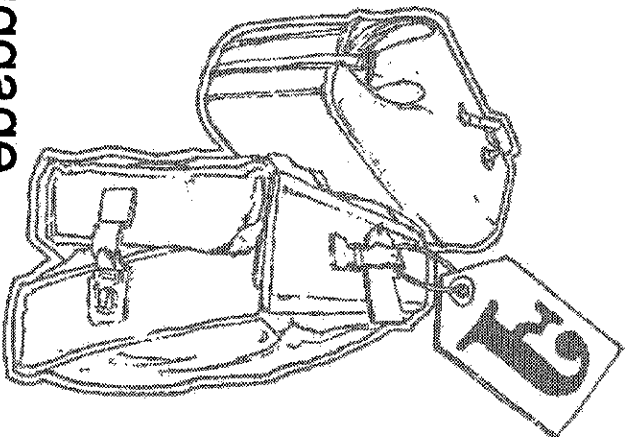

luggage

o

na

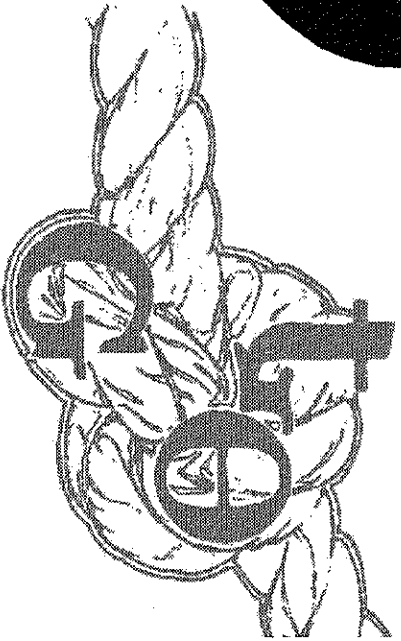

knot

i

v

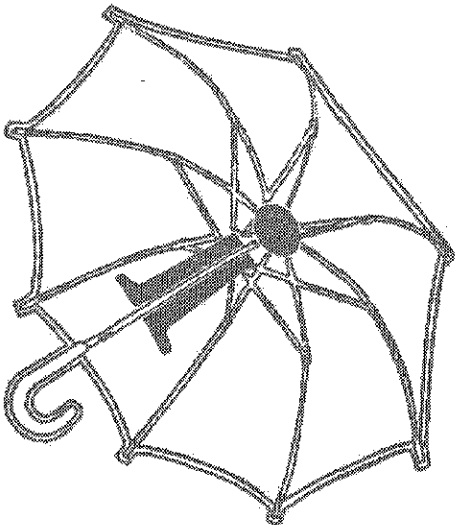

umbrella

t

hna

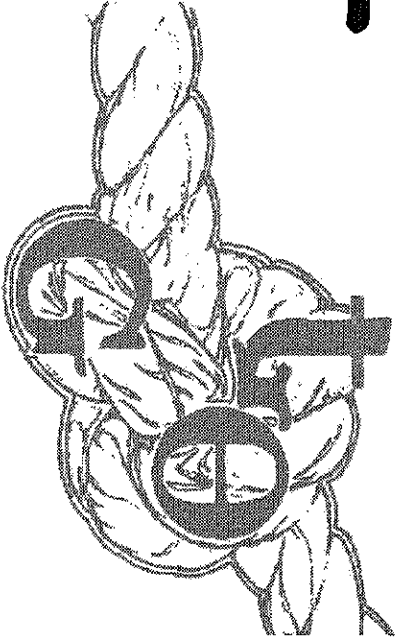

knot

s

ga

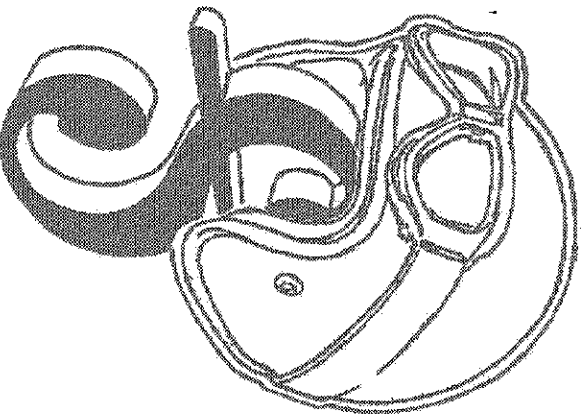

goggles

3

quv

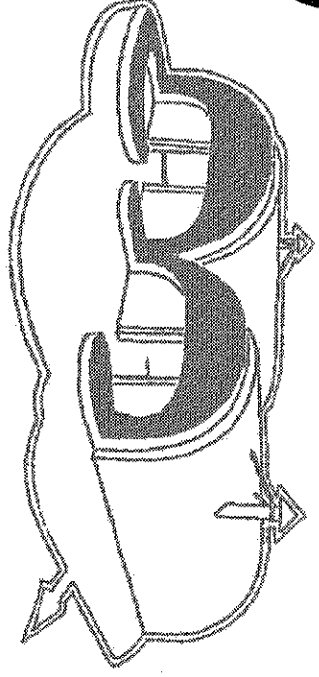

quonset hut

4

quo

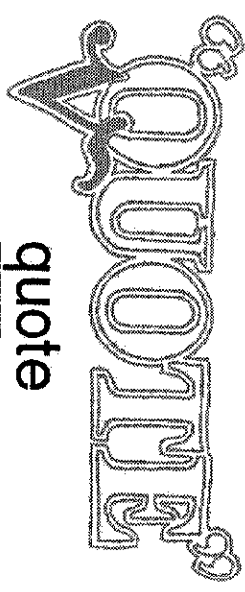

quote

5

sa

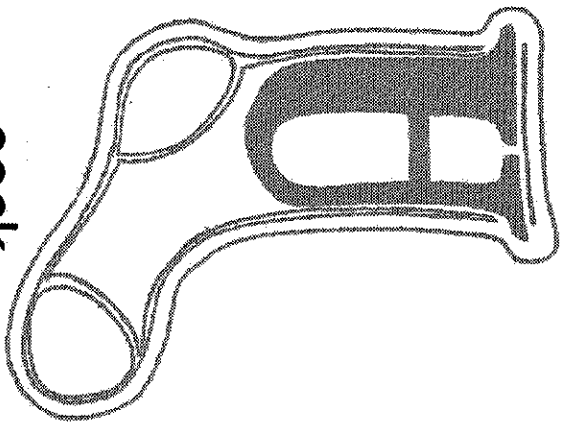

sock

6

quu

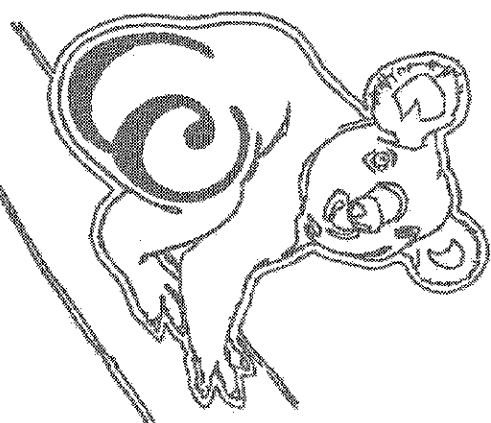

koala

G

tsa

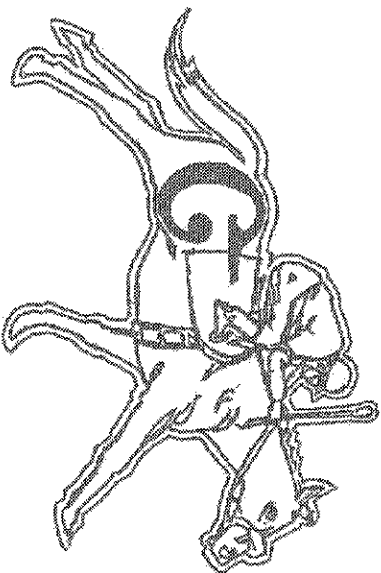

jockey

W

flu

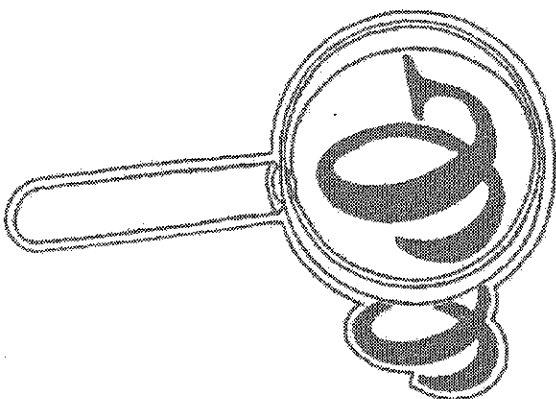

clue

A

tse

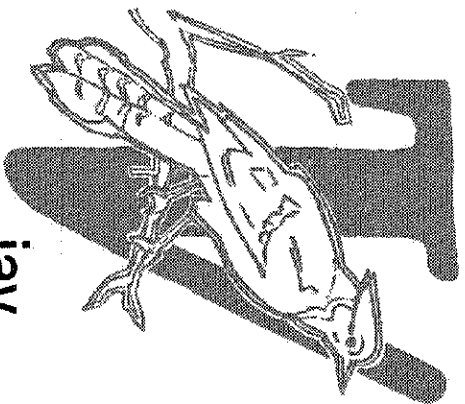

jay

P

tlv

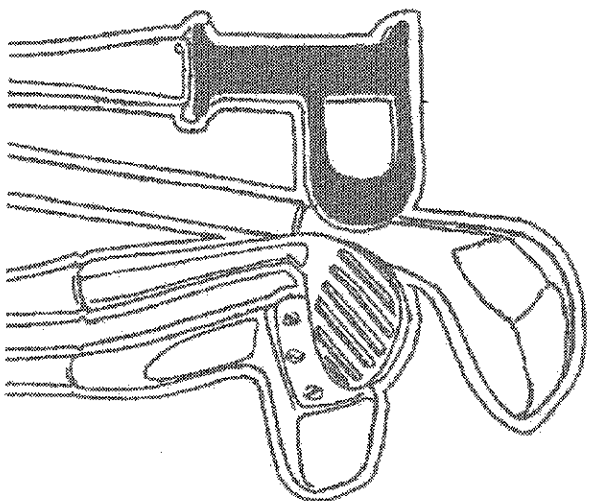

clubs

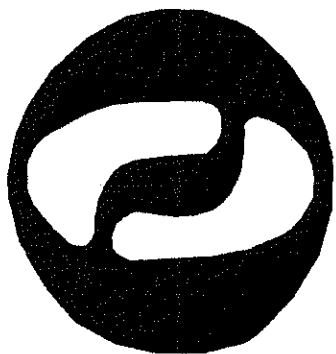

wi

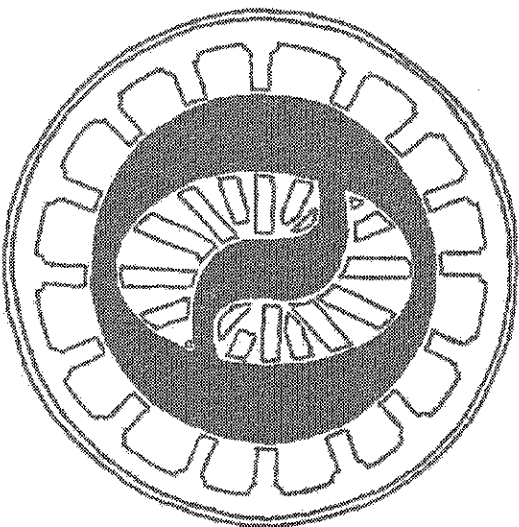

wheel

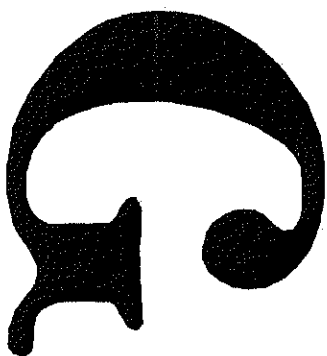

wa

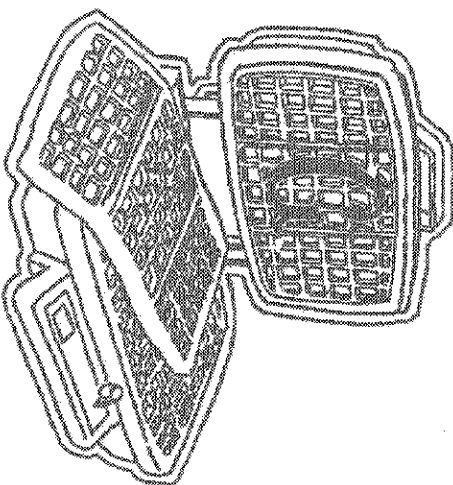

waffle

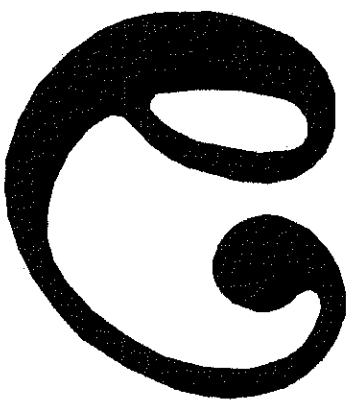

wo

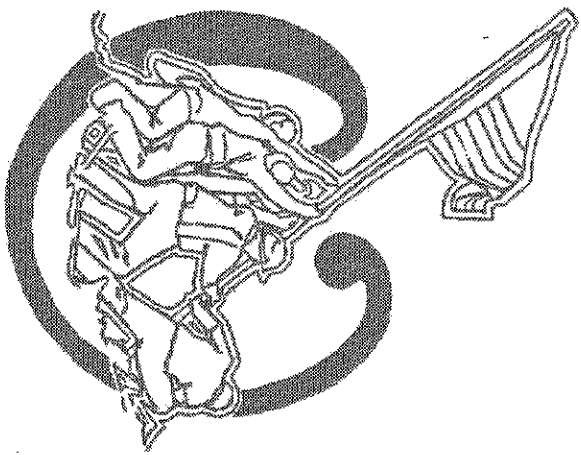

wo jima

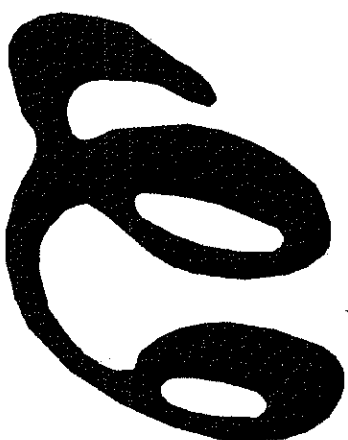

we

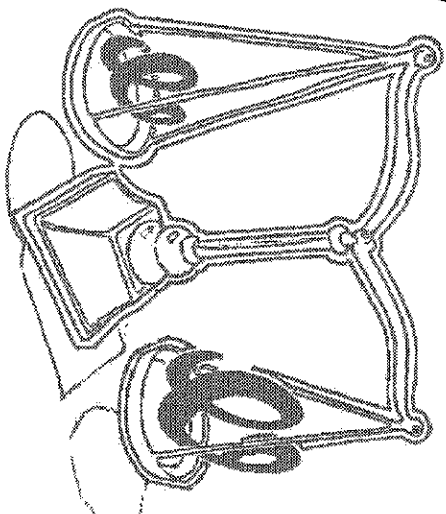

weigh

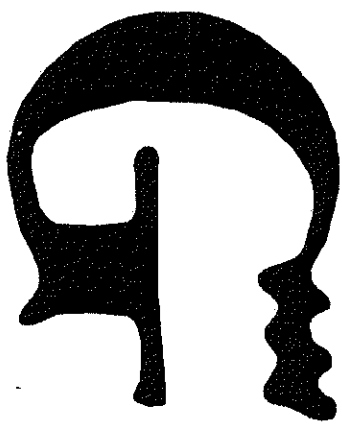

yu

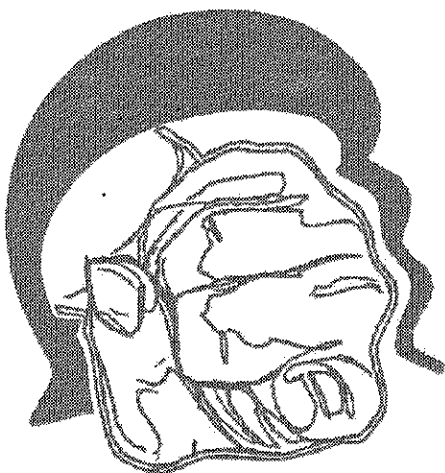

you

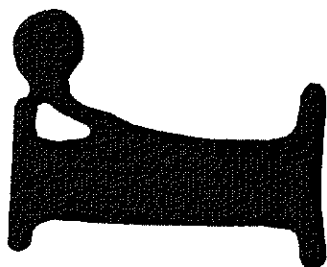

di

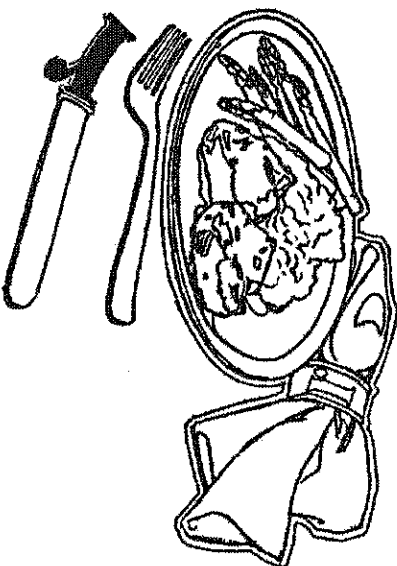

dinner



yv

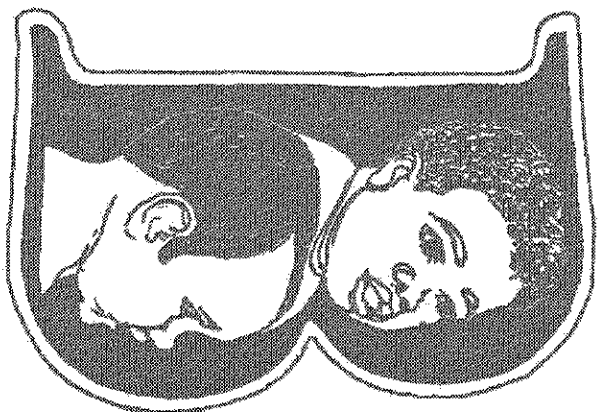

young babies

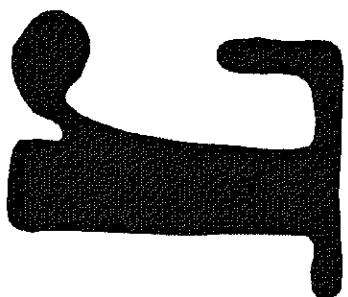

ti

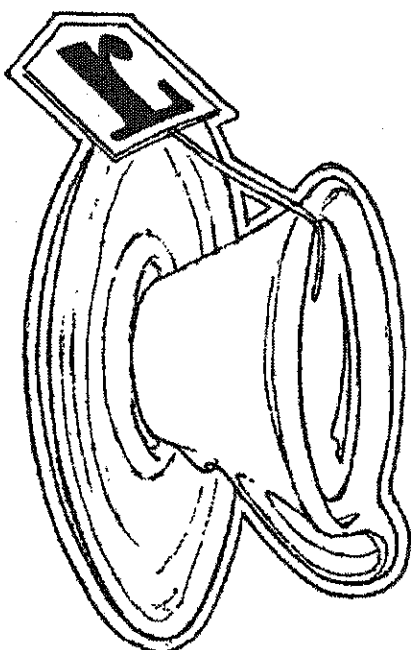

tea

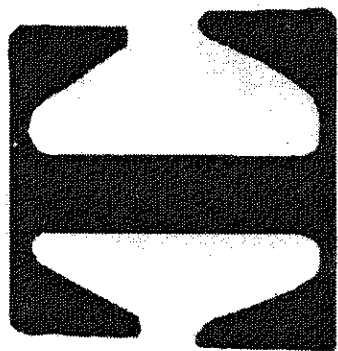

qua

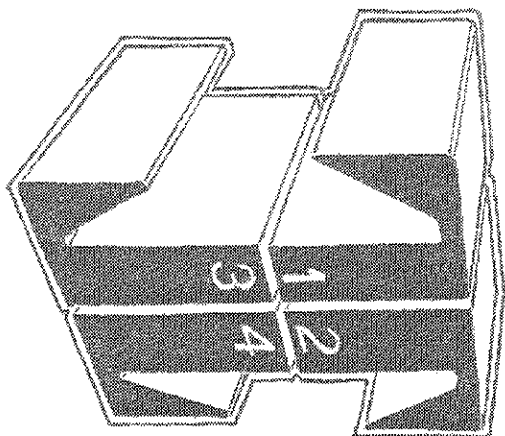

quadrangle

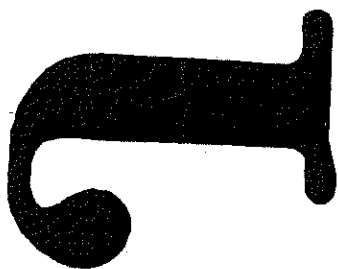

da



doc

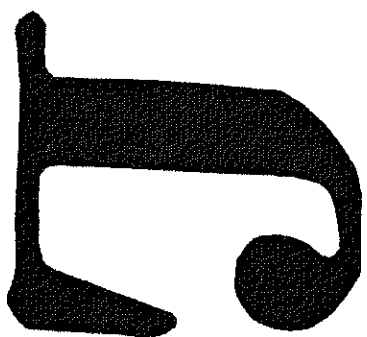

tla

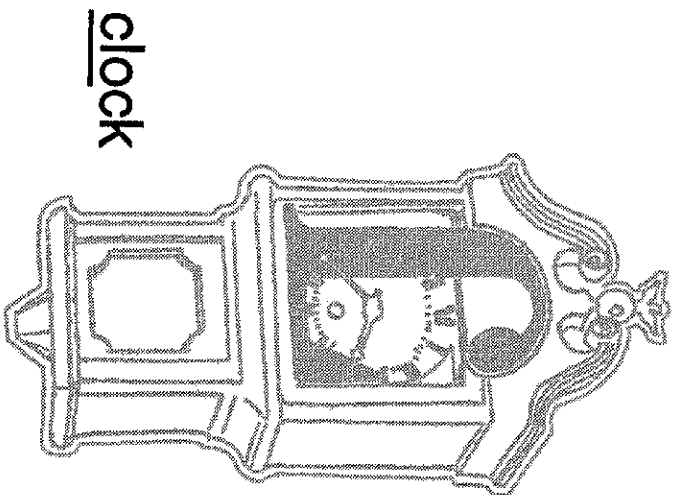

clock

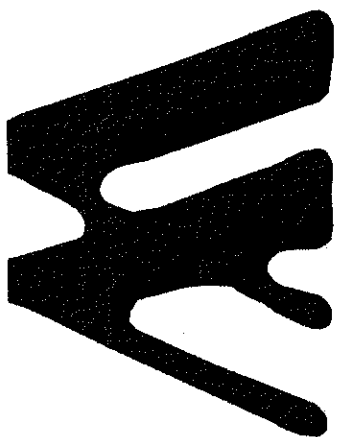

ta

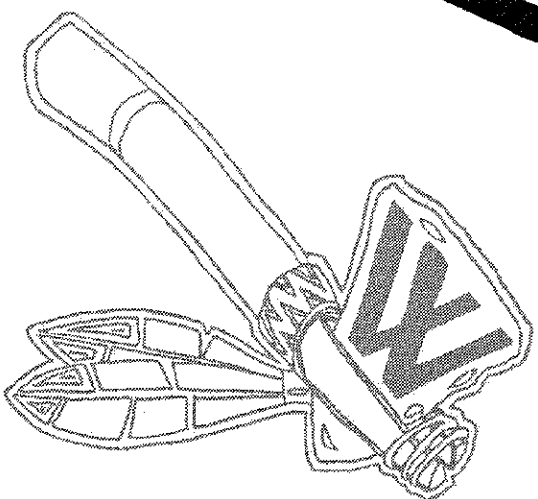

tomahawk

V

do

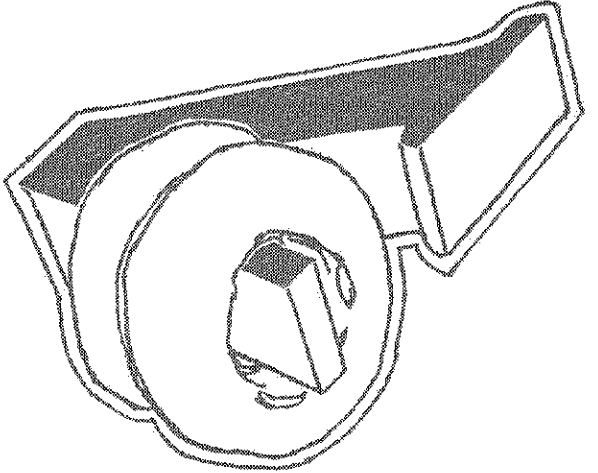

donuts

H

ni

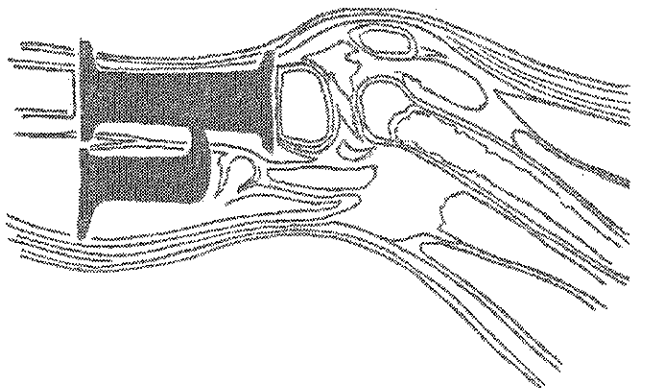

knee

S

du

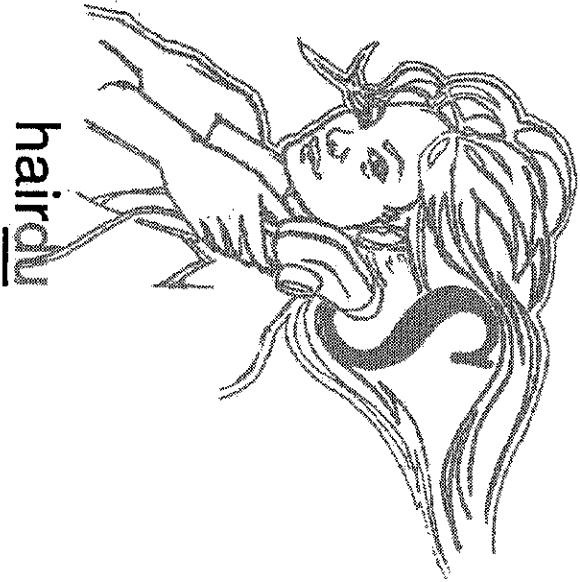

hairdu

Z

no



no

sew

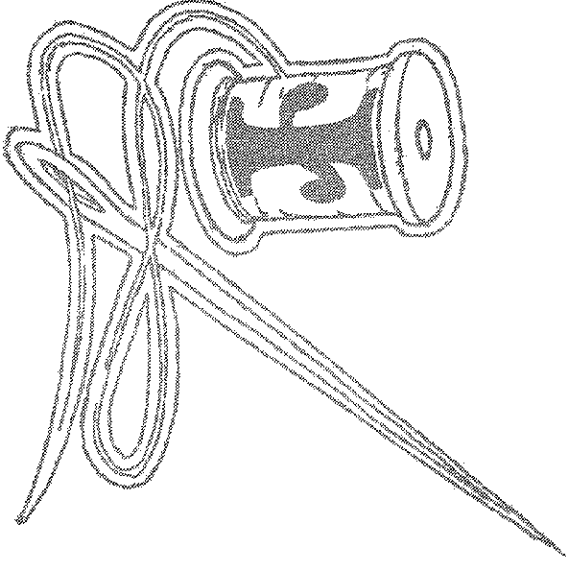

so

S

see

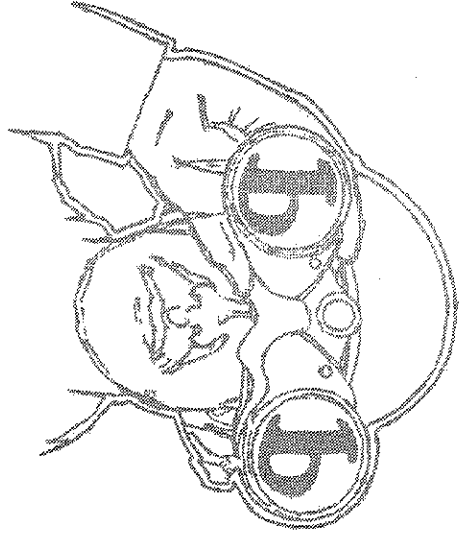

si

S

nuts

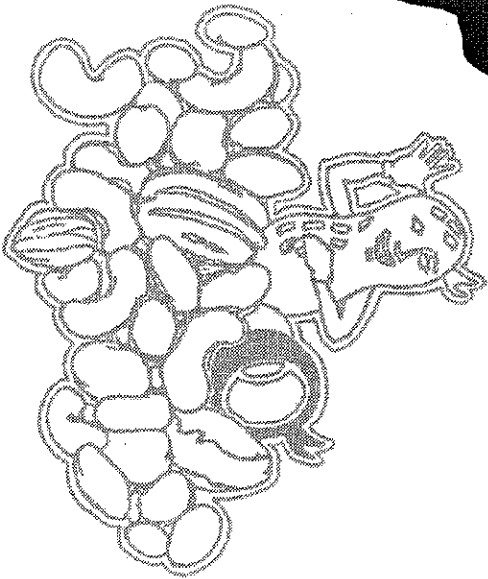

nu

Q

New York

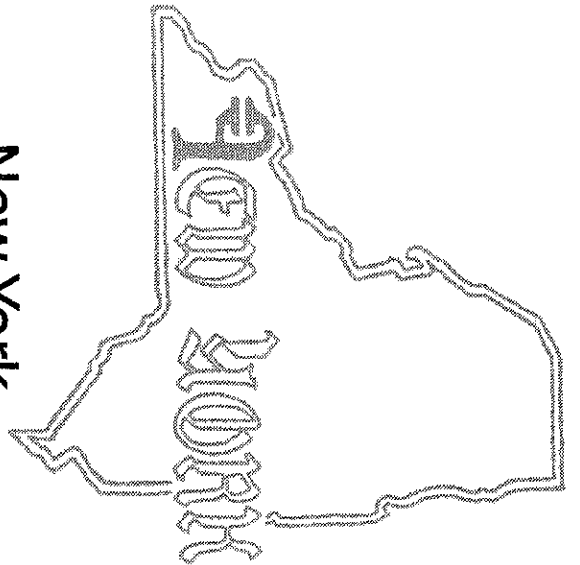

nu

E



dv

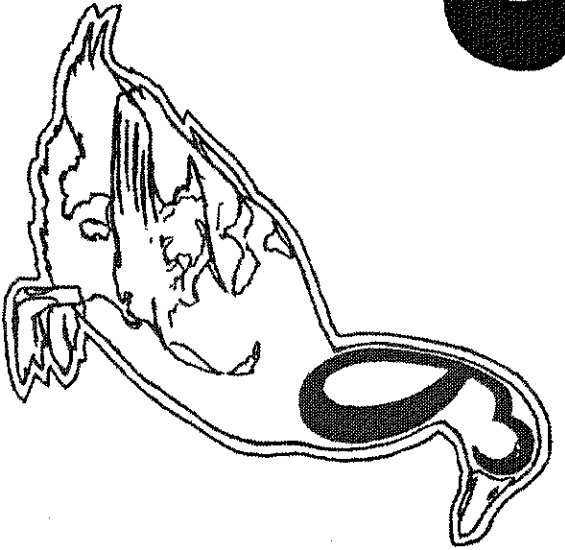

duck

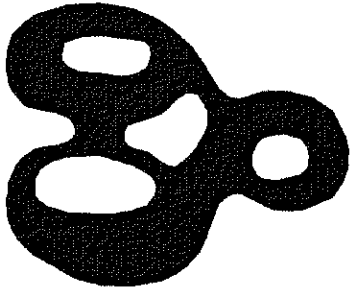

dia

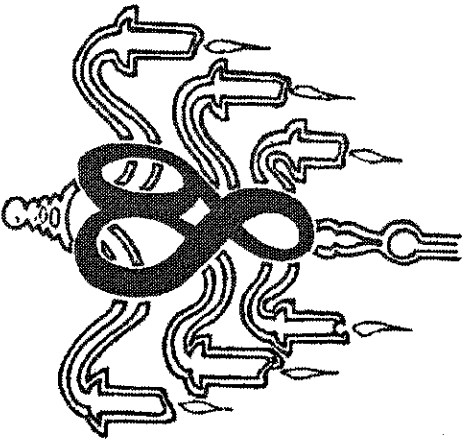

candelabra

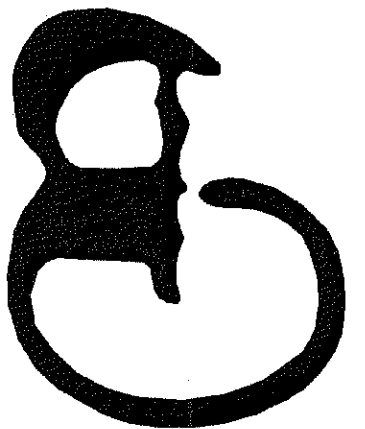

ya

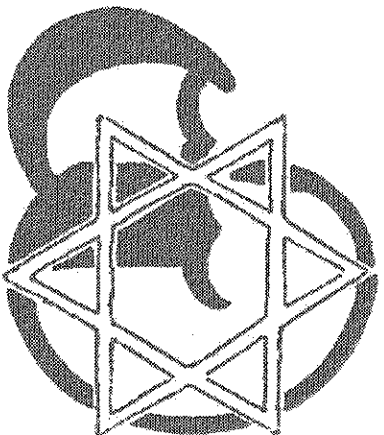

Yahweh



ye

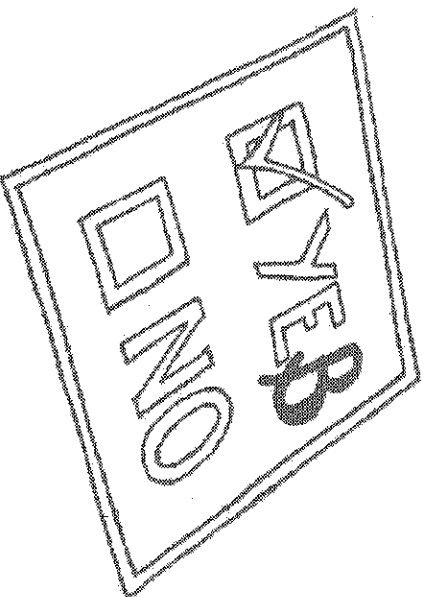

yes

wv

6

wu

6

lowā

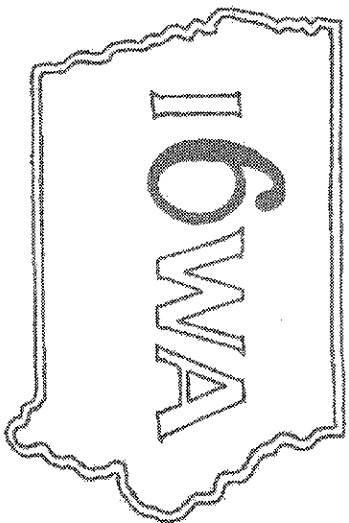

wound

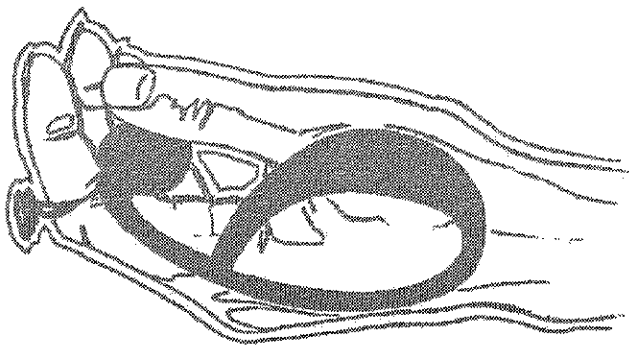

tsv

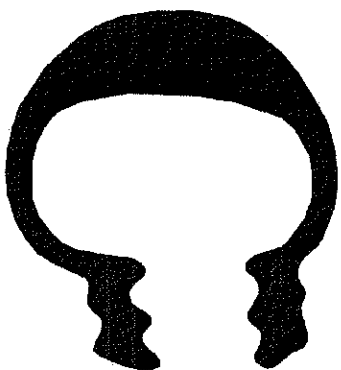

tsu

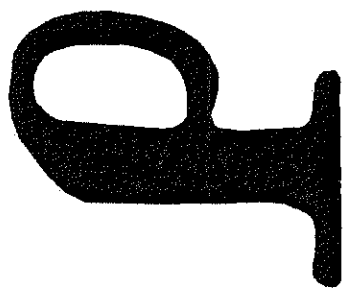

jug

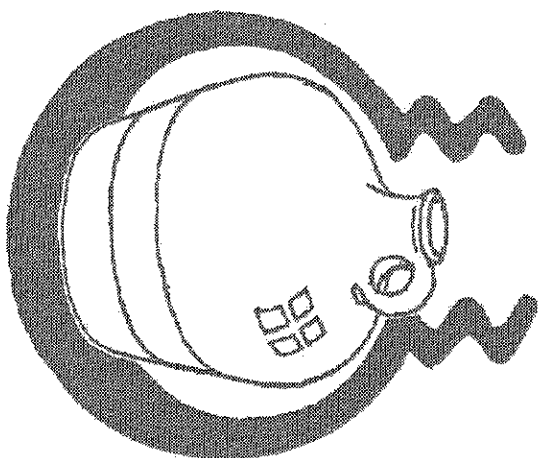

jewel

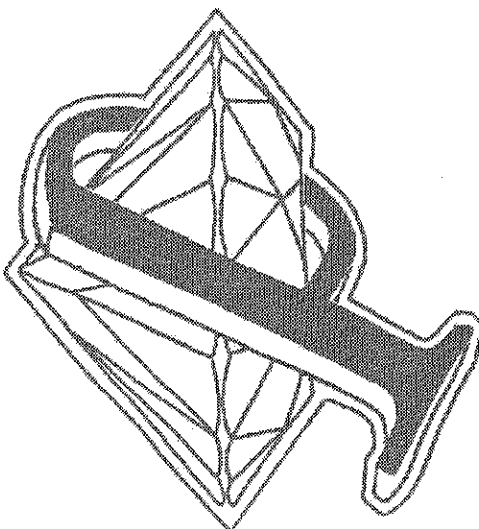

tsi

tsi

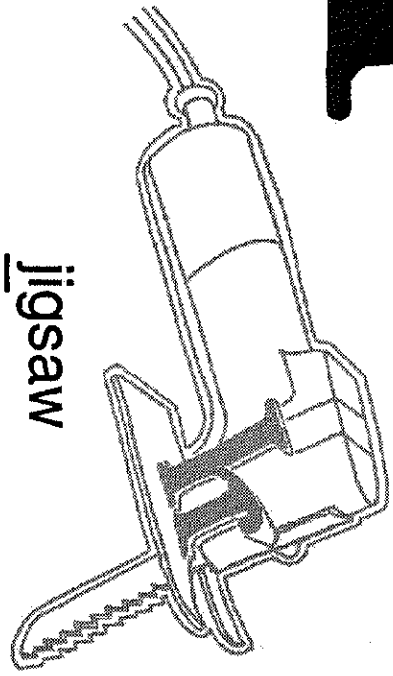

jigsaw

tli

tli

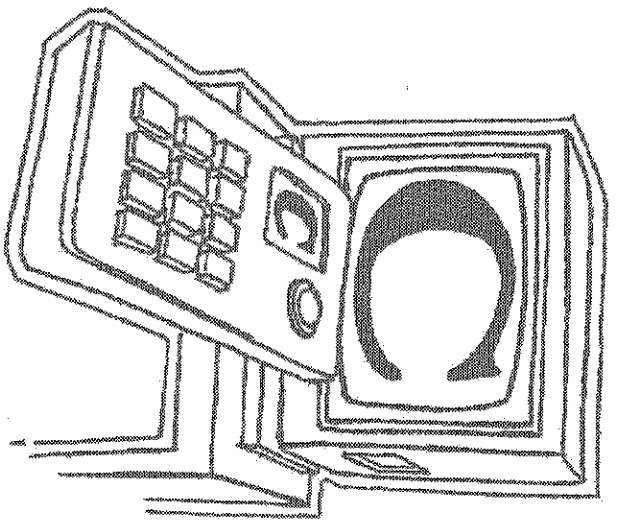

clicker

tso

tso

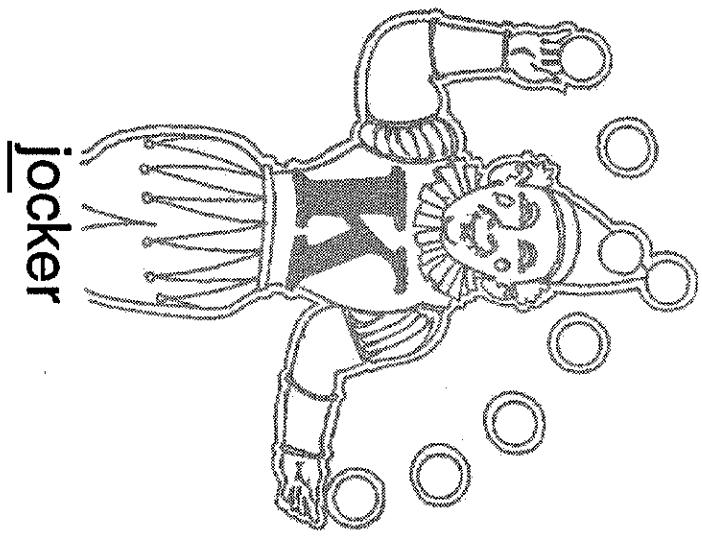

jocker

flo

flo

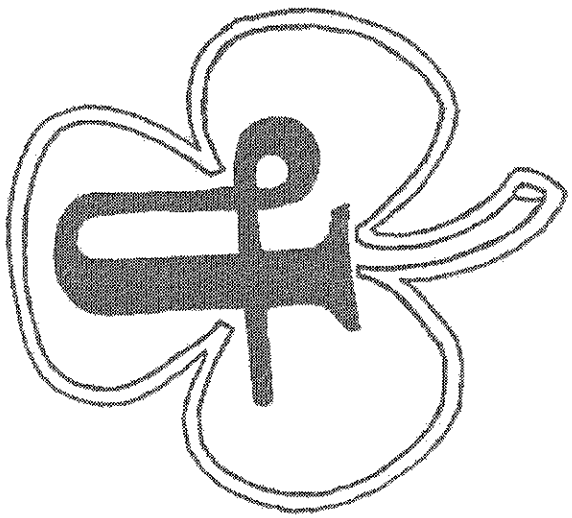

clover

s

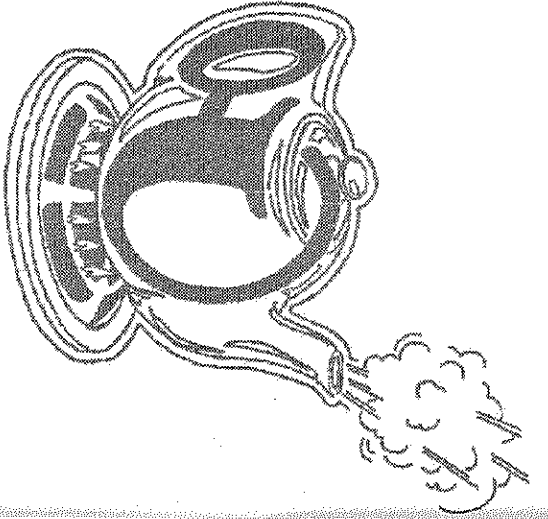

sssteam

que

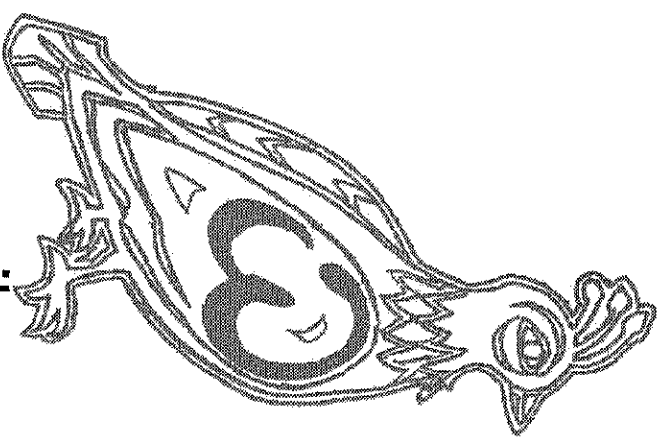

quail

se

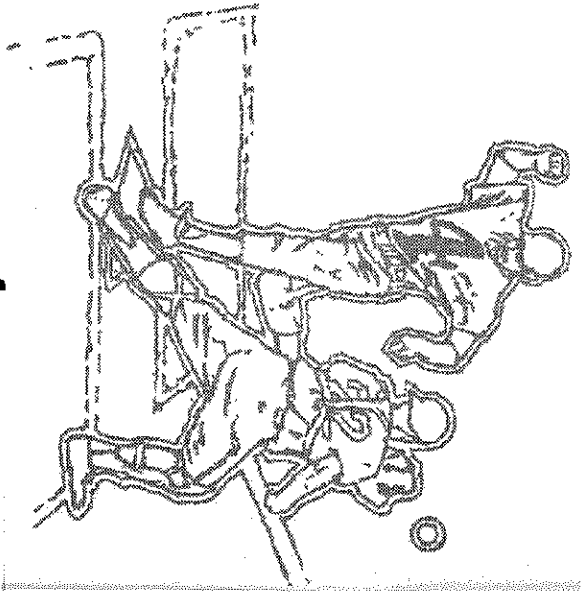

safe

qui

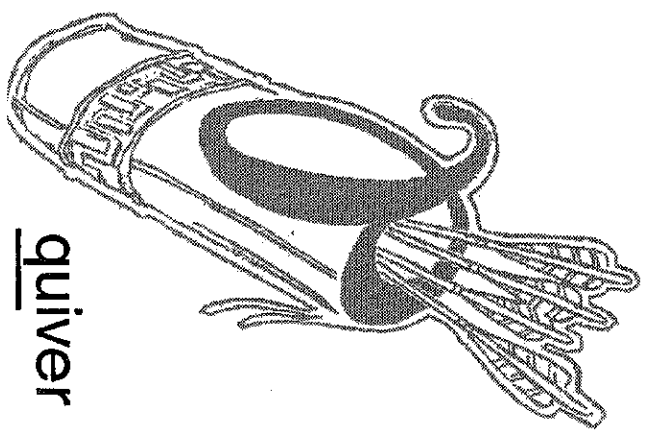

quiver

o

o



Ohio

o

o

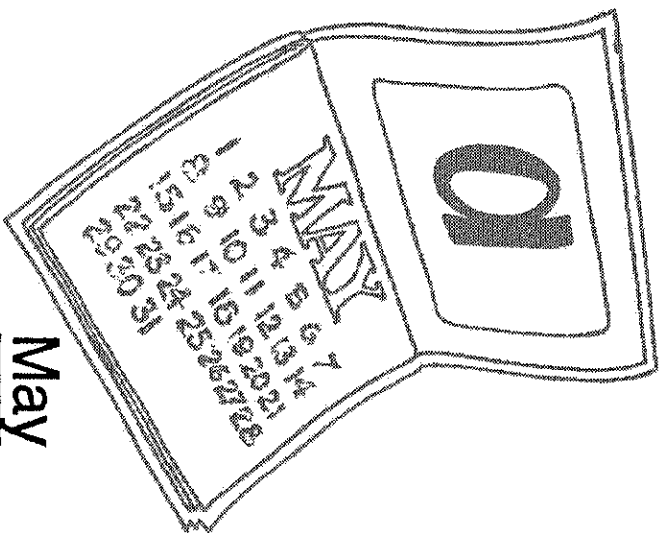

May

i

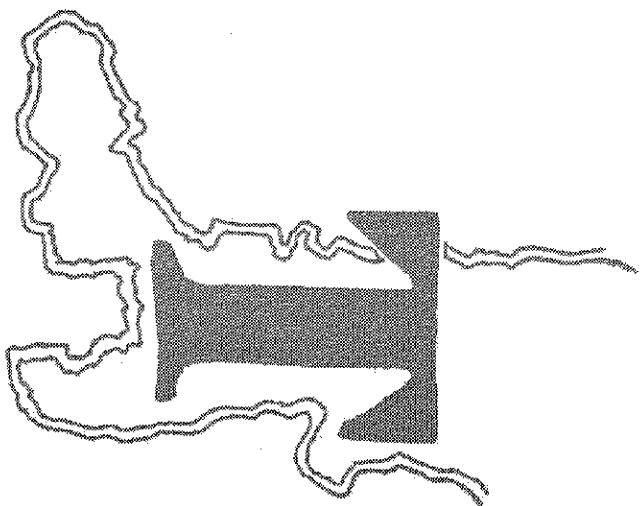

Italy

i

i



i

lu

lu

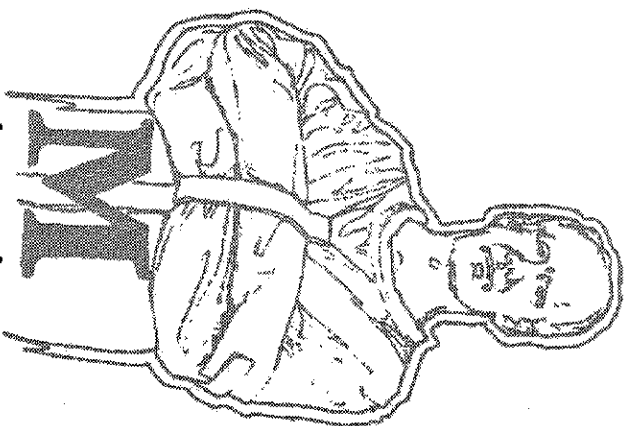

lunatic

ho

ho

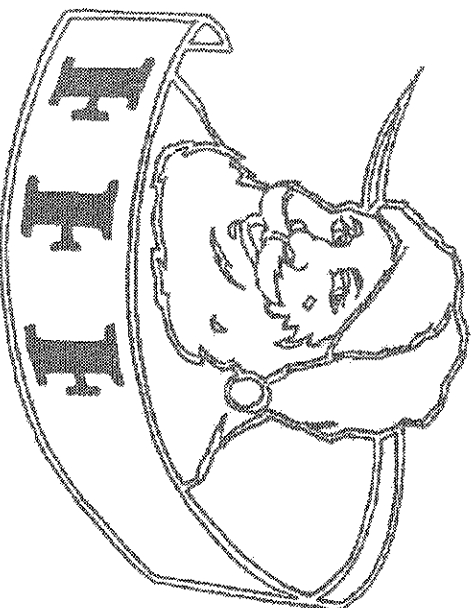

ho, ho, ho

ma

ma

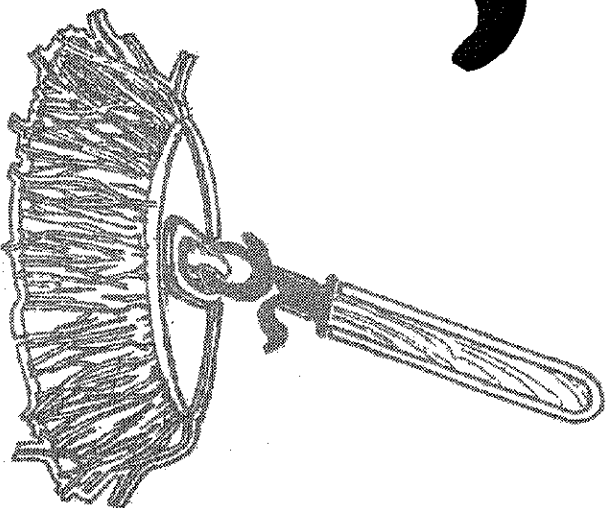

mop

u

u



hula hoop

la

la

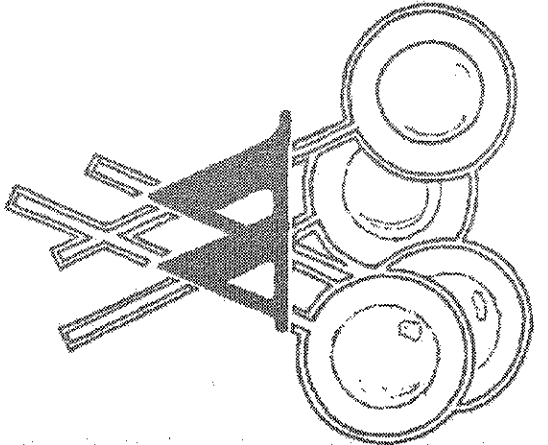

lollipop

yo

yo

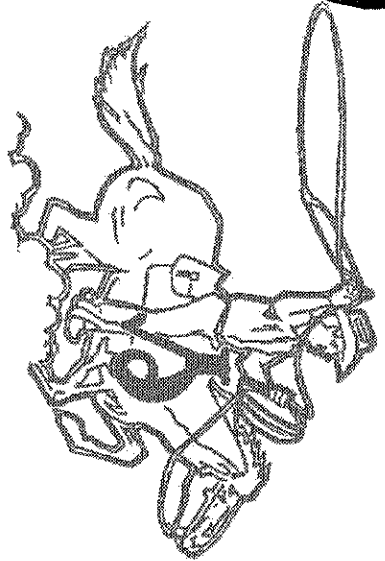

yo-yo

leaf

leaf



leaf

yippee

yippee

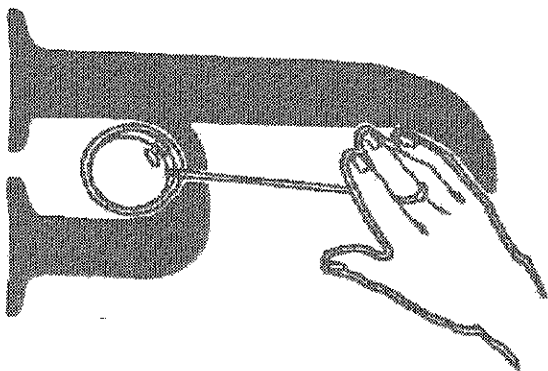

yippee

ha

ha



hop

he

he

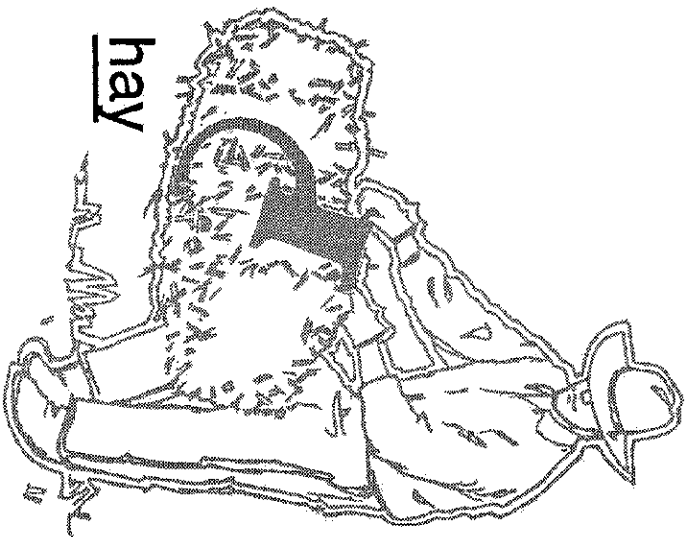

hay

er

e

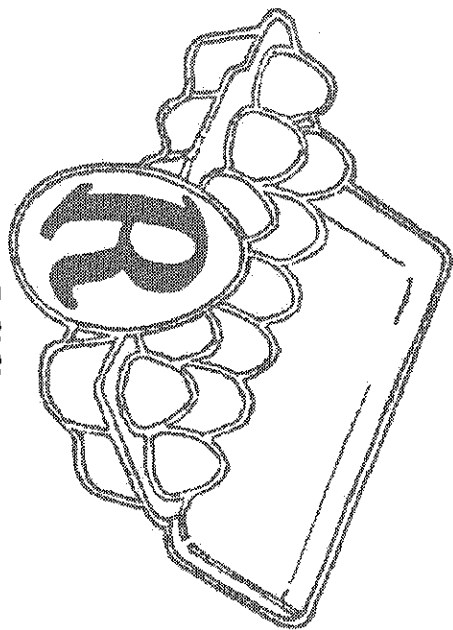

egg

ah

a

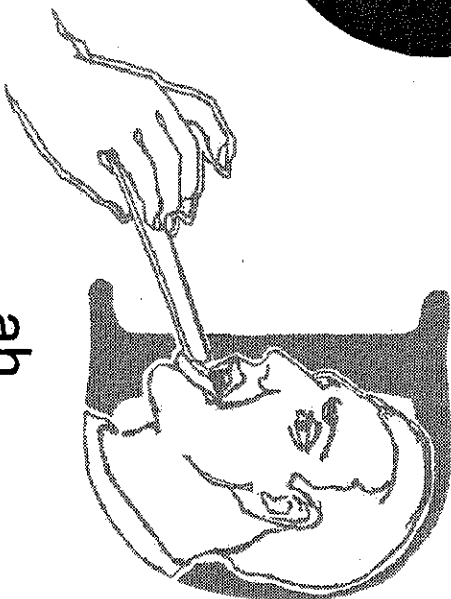

ah

G

nah

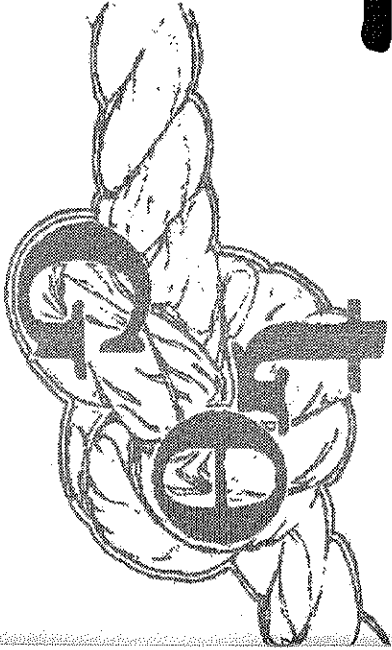

knot

g

su



sue

N

ne

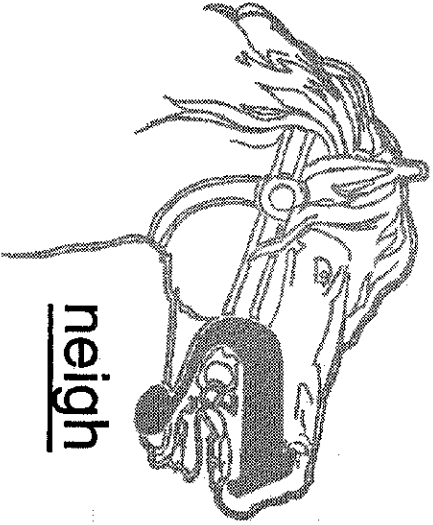

neigh

R

sv

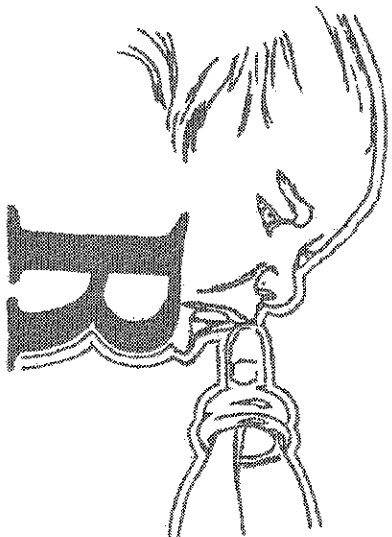

suck